

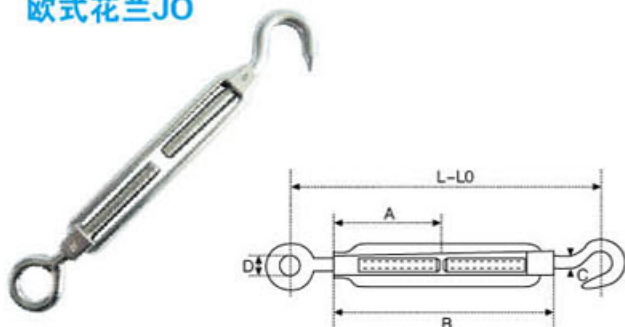

### EU Type Turnbuckle 欧式花兰JO



SIZE	A	B	C	D	L	L1	WLL(T)
4	30	58	5	6.5	80	131	0.025
5	34	70	6	8	96	146	0.04
6	44	90	8	10	122	190	0.10
8	58	120	12	14	164	255	0.20
10	73	150	13	16	205	325	0.30
12	97	200	15	18	264	425	0.50
14	110	225	18	20	300	486	0.70
16	122	250	20	26	337	548	0.80
20	147	300	25	30	406	646	1.20

### EU closed Body Turnbuckle 欧式封闭花兰

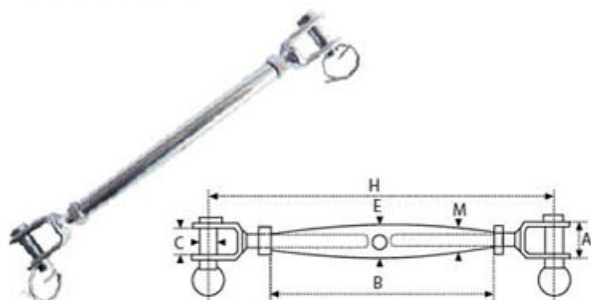

SIZE	M	A	B	C	D	E	H
5	5	12.5	80	7.5	4.8	8.5	128
6	6	15	92	9	5.8	10	145
8	8	17	112	11	7.8	13.5	174
10	10	20	120	12	9.8	17	204
12	12	24	150	15	11.8	21	256
14	14	28	170	18	13.8	23	290
16	16	32.6	190	21	15.8	27	327
20	20	37	210	24	19.8	33	380
22	22	--	--	--	21.8	--	--
24	24	--	--	--	23.8	--	--
36	36	69	300	45	35	--	584

### Turnbuckle DIN1480 德式开体花兰

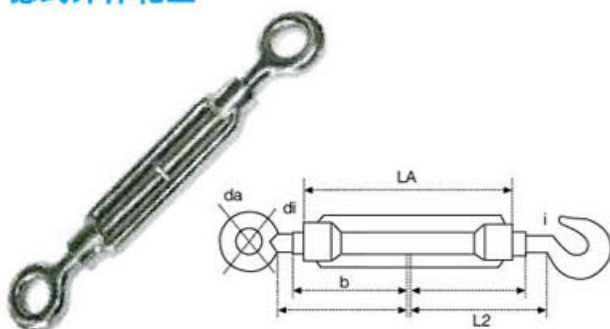

SIZED	LA	L2	m	b	da	di	i	W.L.L.
mm	mm	mm	mm	mm	mm	mm	mm	T
M6	110	60	10	53	10	20	4.5	0.200
M8	110	60	14	55	12	26	6.5	0.400
M10	125	65	20	60	14	30.5	8	0.650
M12	125	75	21	70	18	37.5	10.5	0.900
M16	170	100	27	90	22	48	13	1.800
M20	200	115	34	100	25	51	20	2.750
M24	255	140	39	130	28	66	27	3.990
M30	255	145	45	130	35	83	31	6.250
M32	295	160	55	150	36.5	88	33	6.500
M36	295	160	55	150	44	104	40	9.000
M38	330	185	63	170	42	104	39	9.500

### US Type turnbuckle Hook And Eys 美式钩眼开体花兰

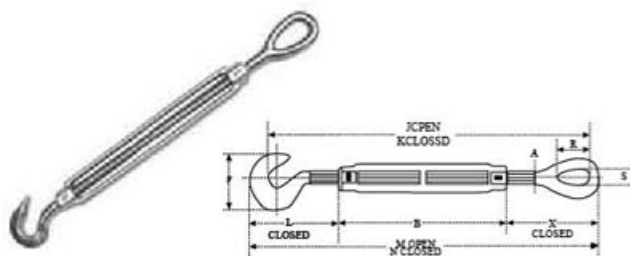

SIZE	Wll (lbs)	A	D	E		J	K	F	BB	R	S	X
				Closed	Open							
1/4x4400	400	0.25	0.45	1.59	11.46	7.46	1.27	4.00	0.78	0.34	1.75	Closed
5/16x41/2	700	0.31	0.50	1.94	13.19	8.69	1.50	4.50	0.94	0.44	2.09	Closed
3/8x6	1000	0.38	0.56	2.30	16.5	10.98	1.77	6.00	1.12	0.53	2.52	Closed
1/2x6	1500	0.50	0.66	2.94	18.45	12.45	2.28	6.00	1.44	0.72	3.23	Closed
1/2x9	1500	0.50	0.66	2.94	24.45	15.45	2.28	9.00	1.44	0.72	3.23	Closed
1/2x12	1500	0.50	0.66	2.94	30.45	18.45	2.28	12.00	1.44	0.72	3.23	Closed
5/8x6	2250	0.63	0.84	3.69	19.96	13.96	2.81	6.00	1.75	0.88	3.90	Closed
5/8x9	2250	0.63	0.84	3.69	25.96	16.96	2.81	9.00	1.75	0.88	3.90	Closed
5/8x12	2250	0.63	0.84	3.69	31.96	19.96	2.81	12.00	1.75	0.88	3.90	Closed
3/4x6	3000	0.75	0.98	4.52	21.63	15.63	3.33	6.00	2.09	1.00	4.69	Closed
3/4x9	3000	0.75	0.98	4.52	27.63	18.63	3.33	9.00	2.09	1.00	4.69	Closed
3/4x12	3000	0.75	0.98	4.52	33.63	21.63	3.33	12.00	2.09	1.00	4.69	Closed
3/4x18	3000	0.75	0.98	4.52	45.63	27.63	3.33	18.00	2.09	1.00	4.69	Closed
7/8x12	4000	0.88	1.13	5.19	34.78	22.78	3.78	12.00	2.38	1.25	5.10	Closed
7/8x18	4000	0.88	1.13	5.19	46.78	28.78	3.78	18.00	2.38	1.25	5.10	Closed
1x6	5000	1.00	1.25	5.84	24.8	18.8	4.25	6.00	3.00	1.44	6.36	Closed



### US Type Turnbuckle Jaw And Jaw 美式叉叉开体花兰

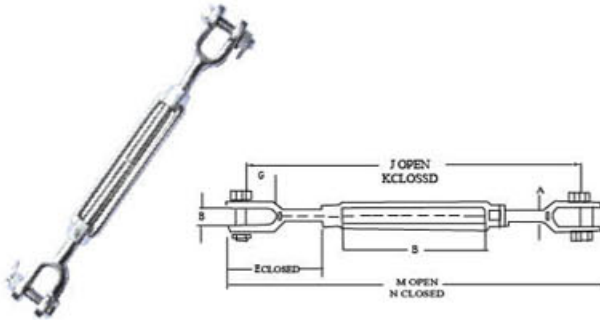

SIZE	WLL		B	J		G	M		N	E	BB
				open	closed		open	closed			
1/4x4	500	0.25	0.41	10.90	6.90	0.62	11.90	7.90	1.58	4.00	
5/16x4 1/2	800	0.31	0.47	12.36	8.36	0.87	13.90	9.40	1.98	4.50	
3/8x6	1200	0.38	0.50	16.14	10.14	0.87	17.38	11.38	2.12	6.00	
1/2x6	2200	0.50	0.63	17.50	11.50	1.06	19.00	13.00	2.75	6.00	
1/2x9	2200	0.50	0.63	23.50	14.50	1.06	25.00	16.00	2.75	9.00	
1/2x12	2200	0.50	0.63	29.50	17.50	1.06	31.00	19.00	2.75	12.00	
5/8x6	3500	0.63	0.75	18.80	12.80	1.31	20.88	14.88	3.50	6.00	
5/8x9	3500	0.63	0.75	24.80	15.80	1.31	26.88	17.88	3.50	9.00	
5/8x12	3500	0.63	0.75	30.80	18.80	1.31	32.88	20.88	3.50	12.00	
3/4x6	5200	0.75	0.94	20.00	14.00	1.50	22.60	16.60	4.18	6.00	
3/4x9	5200	0.75	0.94	26.00	17.00	1.50	28.60	19.60	4.18	9.00	
3/4x12	5200	0.75	0.94	32.00	20.00	1.50	34.60	22.60	4.18	12.00	
3/4x18	5200	0.75	0.94	44.00	26.00	1.50	46.60	28.60	4.18	18.00	
7/8x9	7200	0.88	1.13	33.36	21.36	1.75	36.32	24.32	4.85	12.00	
7/8x18	7200	0.88	1.13	43.36	27.36	1.75	48.32	30.32	4.85	18.00	
1x6	10000	1.00	1.19	22.72	16.72	2.06	26.06	20.06	5.53	6.00	
1x12	10000	1.00	1.19	34.72	22.72	2.06	38.06	26.06	5.53	12.00	

### Frame Type Turnbuckle 日式开体花兰

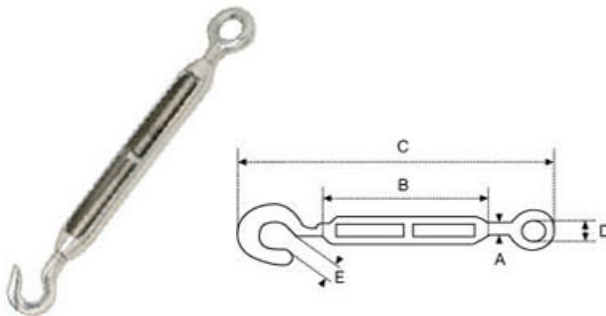

A	B	C	D	E	WLL	WT
mm	mm	mm	mm	mm	Tons	Kgs
5	70	130	8	9	0.1	0.08
6	100	160	10	9	0.25	0.11
8	125	200	12	10	0.35	0.21
10	150	245	16	11	0.5	0.34
12	200	300	20	14	1	0.65
16	250	400	22	18	1.5	1.3
20	300	480	28	20	2.3	2.5
10	325	520	33	22	3.2	3.93
25	350	560	35	26	4.5	5.89

### JIS Closed Body Turnbuckle 日式封闭花兰

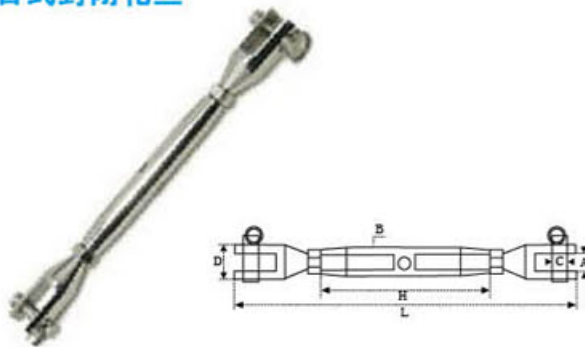

A	B	C	D	E	H	L	WLL
mm	mm	mm	mm	mm	mm	mm	T
4	8	4	10	4	65	120	0.15
5	9	4	11.5	4	70	130	0.25
6	10	5	13	4	78	145	0.35
8	12	7	16	6	88	172	0.70
10	15	8	20	7	99	200	0.10
12	19	10	23	8	125	214	1.50
14	20	10	28	8	149	290	1.90
16	25	12	32	10	170	342	2.20
20	30	16	40	10	220	420	3.10

### Korean Type Turnbuckle 韩式开体花兰



SIZE	A	D	G	H	L	L0
1/4	5.4	11	43	90	124	185
5/16	6.9	14	53	110	154	230
3/8	8.3	17	77.5	160	213	333
1/2	11.1	20	85	175	239	409
5/8	14.2	25	107	220	301	465
3/4	17.2	35	119	242	347	523